

# Chapter 3: STP

CCNA Routing and Switching

Scaling Networks v6.0



# Chapter 3 - Sections & Objectives

- 3.1 Spanning Tree Concepts
  - Build a simple switched network with redundant links.
  - Explain common problems in a redundant, switched network.
  - Build a simple, switched network using STP.
- 3.2 Varieties of Spanning Tree Protocols
  - Explain how different varieties of spanning tree protocols operate.
  - Describe the different spanning tree varieties.
  - Explain how PVST+ operates.
  - Explain how Rapid PVST+ operates.

# Chapter 3 - Sections & Objectives (Cont.)

- 3.3 Spanning Tree Configuration
  - Implement PVST+ and Rapid PVST+ in a switched LAN environment.
  - Configure PVST+ in a switched LAN environment.
  - Configure Rapid PVST+ in a switched LAN environment.
  - Analyze common STP configuration issues.

# 3.1 STP Operation

## Spanning Tree

# Redundancy at OSI Layers 1 and 2

- Switched networks commonly have redundant paths and even redundant links between the same two devices.
  - Redundant paths eliminate a single point of failure in order to improve reliability and availability.
  - Redundant paths can cause physical and logical Layer 2 loops.
- Spanning Tree Protocol (STP) is a Layer 2 protocol that helps especially when there are redundant links.
- Layer 2 loop issues
  - Mac database instability – copies of the same frame being received on different ports.
  - Broadcast storms – broadcasts are flooded endlessly causing network disruption.
  - Multiple frame transmission – multiple copies of unicast frames delivered to the same destination.

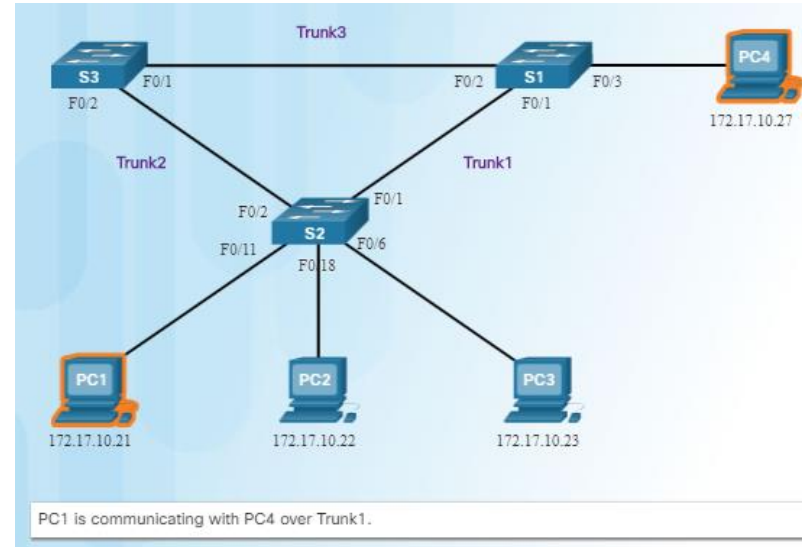

# Issues with Layer 1 Redundancy: MAC Database Instability

- Ethernet frames do not have a time to live (TTL) field like the Layer 3 IP header has. This means that Ethernet has no mechanism to drop frames that propagate endlessly. This can result in MAC database instability.

1. PC1 sends a broadcast frame to S2.
  2. S2 updates the MAC address table for PC1's MAC address on port 11.
  3. S2 forwards the frame out all ports except the port the frame came in on. S1 and S3 receive the frame on a trunk and update their own MAC address tables that PC1 is reachable through the trunk port.
  4. S1 and S3 send the frame out all ports except the port it came in on.
  5. When S1 sends the frame out port 2 (Trunk 3), S3 updates the MAC address table to reflect that PC1 is now reachable through port 1.
- A host caught in a network loop is not accessible to other hosts.
  - Due to constant changes in the MAC address table, Switches S3 and S1 do not know which port to forward frames.

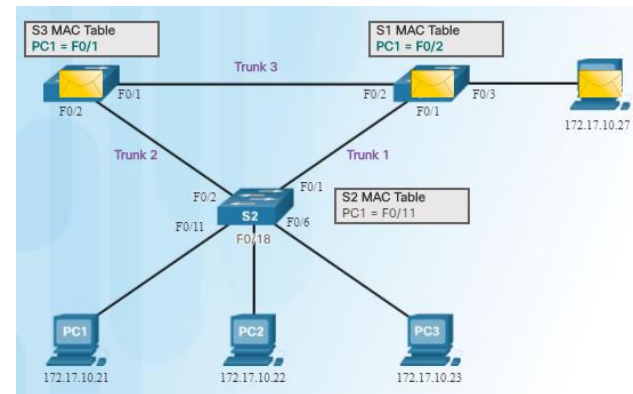
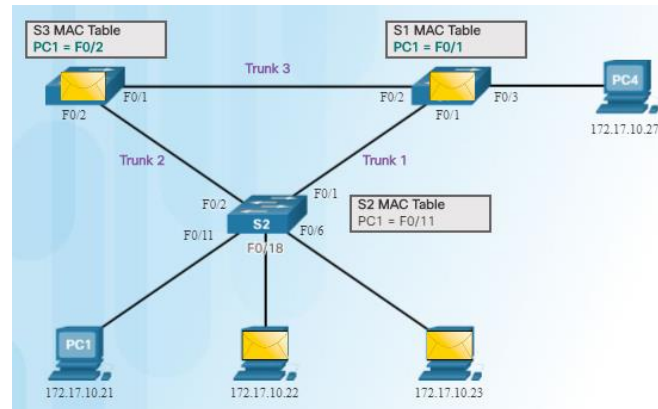

# Issues with Layer 1 Redundancy: Broadcast Storms

- Broadcast storm – so many broadcast frames in a Layer 2 loop that use all available bandwidth and make the network unreachable for legitimate network traffic.
  - Causes a denial of service (DoS)
  - Can develop in seconds and bring the network down

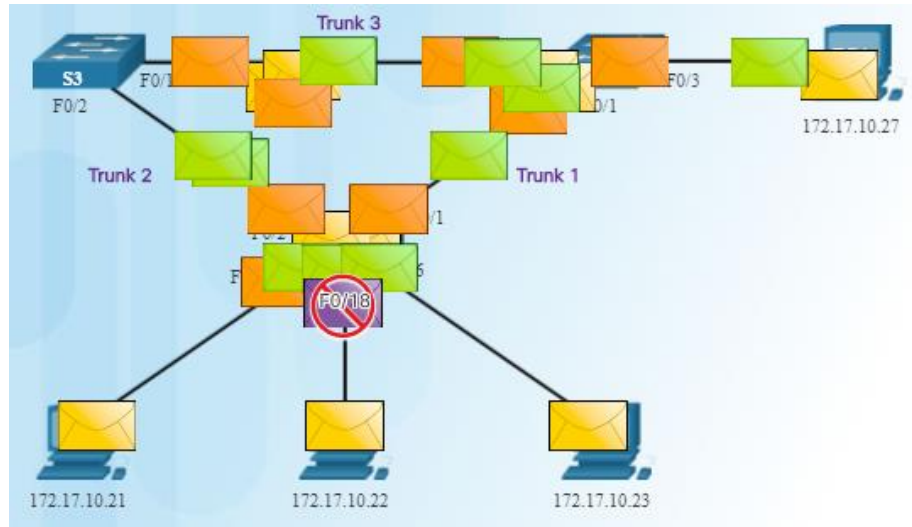

## Issues with Layer 1 Redundancy: Duplicate Unicast Frames

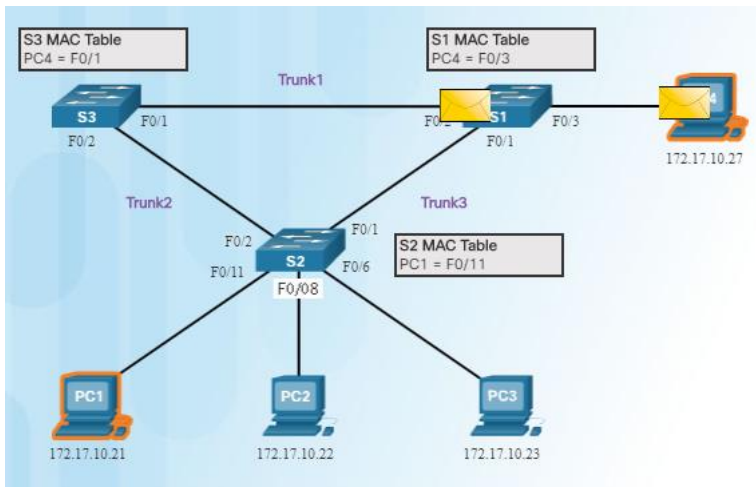

- An unknown unicast frame is when the switch does not have the destination MAC address in its MAC address table and has to broadcast the frame out all ports except the port the frame was received on (the ingress port).
- Unknown unicast frames sent onto a looped network can result in duplicate frames arriving at the destination device.
  1. PC1 sends a frame destined for PC4.
  2. S2 does not have PC4's MAC address in the MAC address table so it forwards the frame out all ports including the trunks that lead to S1 and S3. S1 sends the frame to PC4. S3 also sends a copy of the frame over to S1 which delivers the same frame again to PC4.



## Spanning Tree Algorithm: Introduction

- The Spanning Tree Protocol (STP) creates one logical path through the switch network (all destinations on the network).
  - Blocks redundant paths that could cause a loop.
  - STP sends bridge protocol data units (BPDUs) between Layer 2 devices in order to create the one logical path.
- A port on S2 is blocked so traffic can only flow one way between any two devices.
- When Trunk1 fails, the blocked port on S2 is unblocked and traffic can flow between S2 and S3.

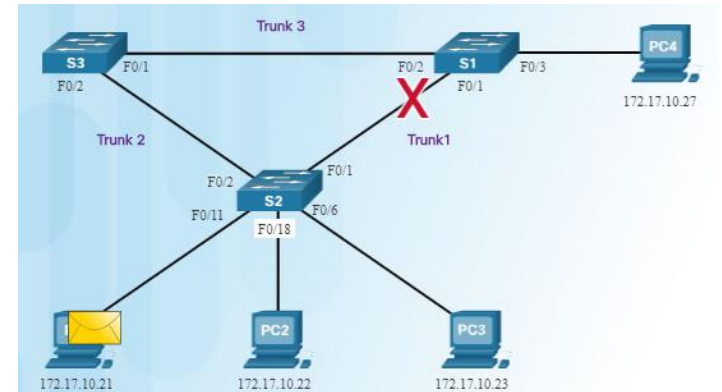
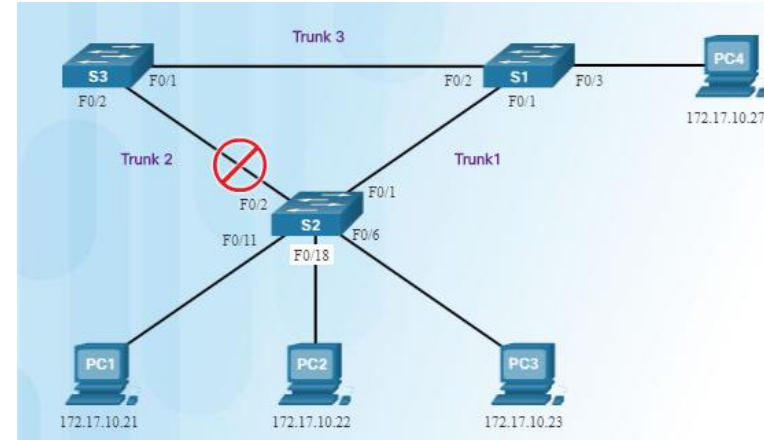

# Spanning Tree Algorithm: Port Roles

- Root bridge – one Layer 2 device in a switched network.
- Root port – one port on a switch that has the lowest cost to reach the root bridge.
- Designated port – selected on a per-segment (each link) basis, based on the cost to get back to root bridge for either side of the link.
- Alternate port – (RSTP only) backup port for the designated port when the other side is not a root port.
- Backup port – (RSTP only) backup port for the root port.

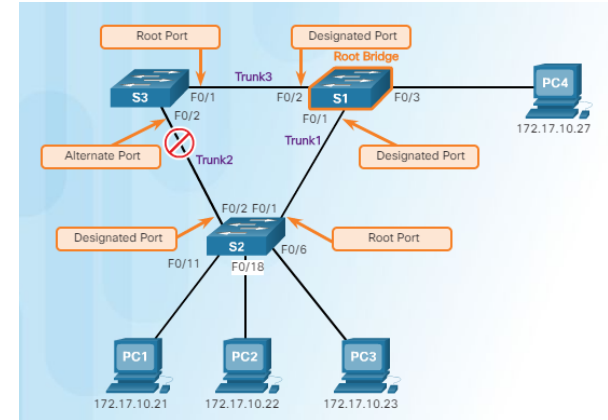

## Spanning Tree Algorithm: Root Bridge



- Lowest bridge ID (BID) becomes root bridge
  - Originally BID had two fields: bridge priority and MAC address
  - Bridge priority default is 32,768 (can change)
  - Lowest MAC address (if bridge priority is not changed) becomes determinant for root bridge.

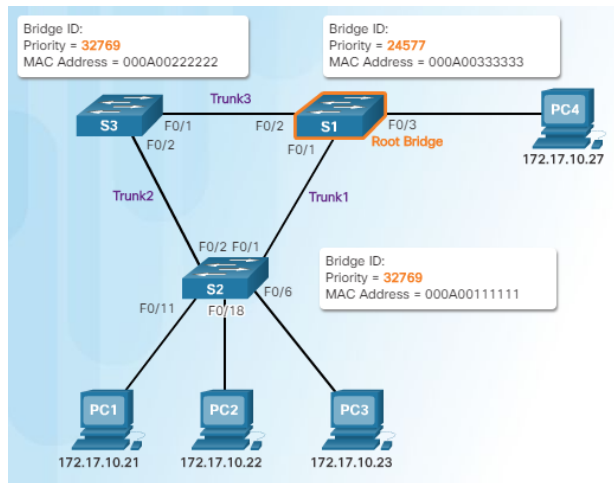
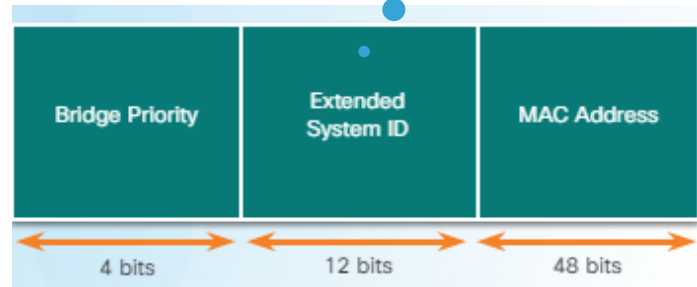

## STP Operation

# Spanning Tree Algorithm: Root Path Cost

- Root path cost is used to determine the role of the port and whether or not traffic is blocked.
- Can be modified with the **spanning-tree cost** interface command.

Link Speed	Cost (Revised IEEE Specification)	Cost (Previous IEEE Specification)
10 Gb/s	2	1
1 Gb/s	4	1
100 Mb/s	19	10
10 Mb/s	100	100

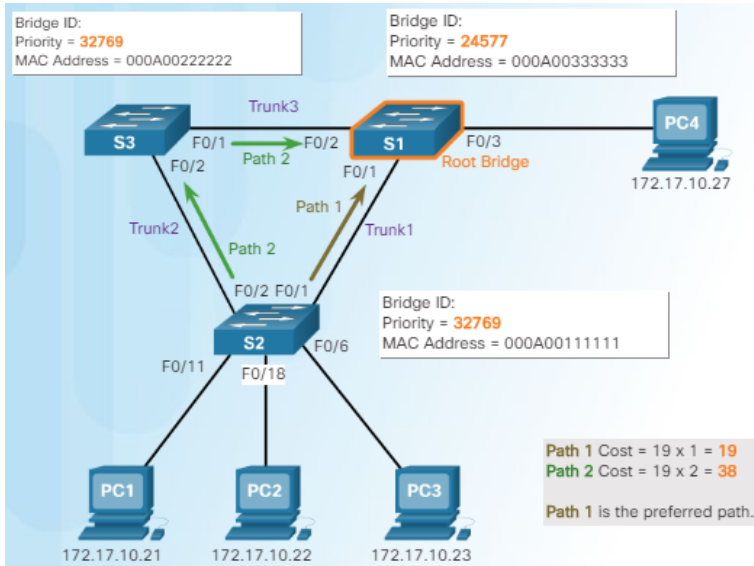

```
S2# configure terminal
Enter configuration commands, one per line. End with CNTL/Z.
S2(config)# interface f0/1
S2(config-if)# spanning-tree cost 25
```

```
S2(config)# interface f0/1
S2(config-if)# no spanning-tree cost
```

```
S2# show spanning-tree

VLAN001
Spanning tree enabled protocol ieee
Root ID    Priority 24577
Address    000A.0033.3333
Cost       19
Port       1
Hello Time 2 sec Max Age 20 sec Forward Delay 15 sec

Bridge ID  Priority    32769 (priority 32768 sys-id-ext 1)
Address    000A.0011.1111
Hello time 2 sec Max Age 20 sec Forward Delay 15 sec
Aging Time 300

Interface  Role  Sts  Cost   Prio.Nbr  Type
-----
F0/1      Root  FWD  19     128.1     Edge P2p
F0/2      Desg  FWD  19     128.2     Edge P2p
```

# STP Operation

## Port Role Decisions for RSTP

- S1 is root bridge

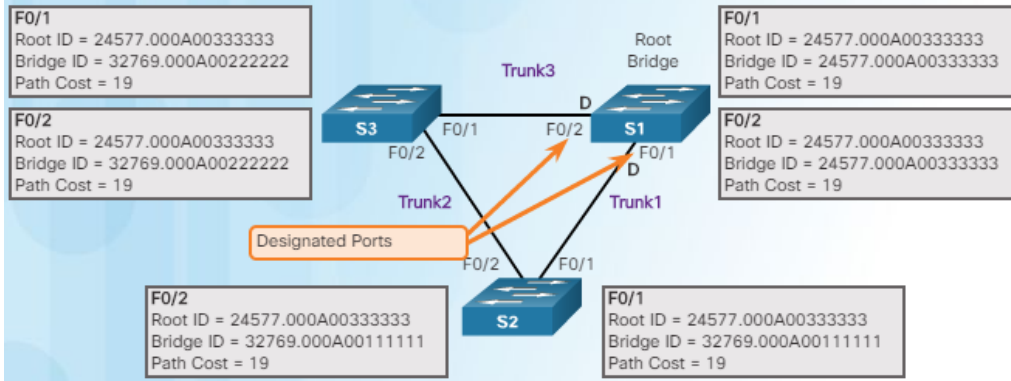
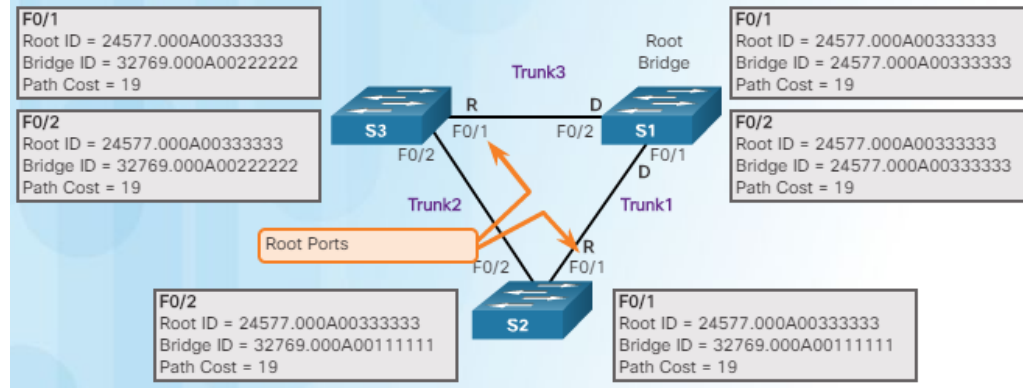

## STP Operation

# Port Role Decisions for RSTP (Cont.)

Which switch (S3 or S2) has the lowest BID?

Which port is the designated port?

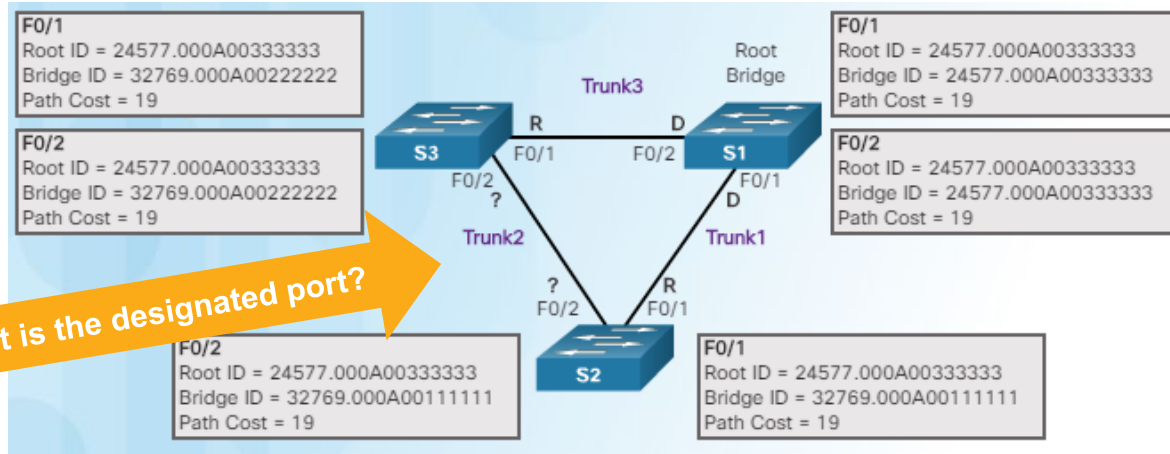

- After S3 and S2 exchange BPDUs, STP determines that the F0/2 port on S2 becomes the designated port and the S3 F0/2 port becomes the alternate port, thus going into the blocking state so there is only one path through the switched network.

## STP Operation

# Determine Designated and Alternate Ports

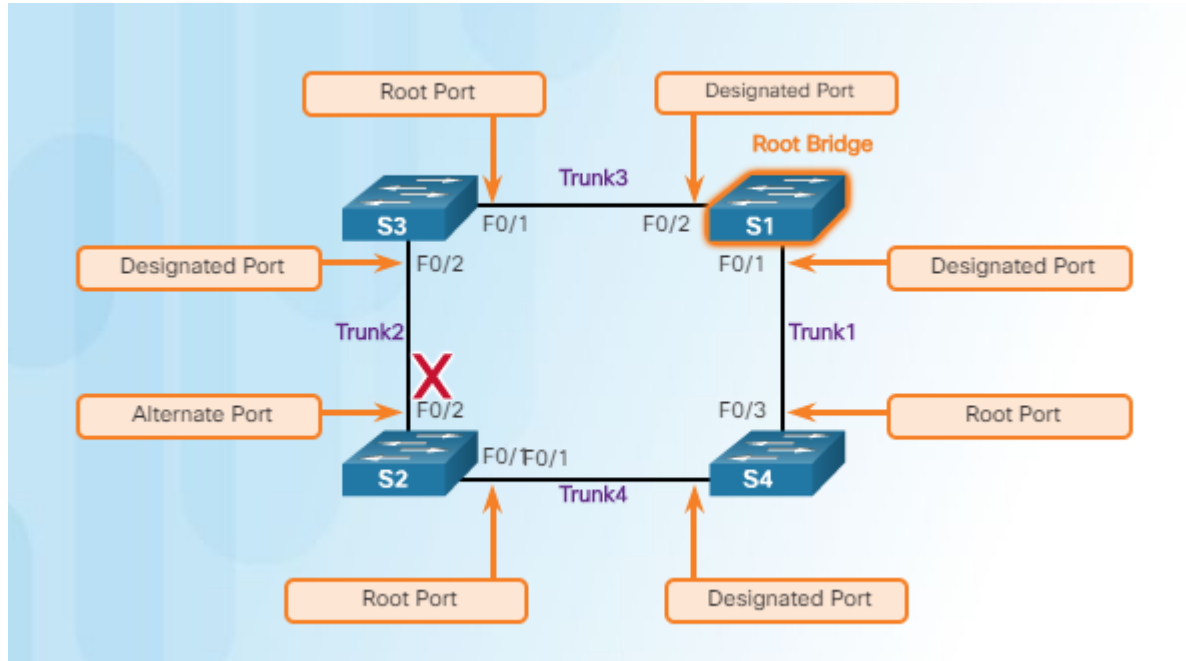

Remember port states are based on path cost back to root bridge.

## 802.1D BPDU Frame

## Format

Field Number	Bytes	Field
1-4	2	Protocol ID
	1	Version
	1	Message Type
	1	Flags
5-8	8	Root ID
	4	Root Path Cost
	8	Bridge ID
	2	Port ID
9-12	2	Message Age
	2	Max Age
	2	Hello Time
	2	Forward Delay

```

Frame 1 (60 bytes on wire, 60 bytes captured)
  IEEE 802.3 Ethernet
    Destination: Spanning-tree-(for-bridges)_00 (01:80:c2:00:00:00)
    Source: Cisco_9e:93:03 (00:19:aa:9e:93:03)
    Length: 38
    Trailer: 0000000000000000
  Logical-Link Control
    Spanning Tree Protocol
      Protocol Identifier: Spanning Tree Protocol (0x0000)
      Protocol version Identifier: Spanning Tree (0)
      BPDU Type: Configuration (0x00)
    BPDU flags: 0x01 (Topology change)
      Root Identifier: 24577 / 00:19:aa:9e:93:00
      Root Path Cost: 0
      Bridge Identifier: 24577 / 00:19:aa:9e:93:00
      Port Identifier: 0x8003
      Message Age: 0
      Max Age: 20
      Hello Time: 2
      Forward Delay: 15
  
```

Field	Description
Protocol ID	Type of protocol being used; set to 0
Version	Protocol version; set to 0
Message type	Type of message; set to 0
Flags	Topology change (TC) bit signals a topology a change; topology change acknowledgment (TCA) bit used when a configuration message with the TC bit set has been received
Root ID	Root bridge information
Root path cost	Cost of the path from the switch sending the configuration message to the root bridge
Bridge ID	Includes priority, extended system ID, and MAC address ID of the bridge sending the message
Port ID	Port number from which the BPDU was sent
Message age	Amount of time since the root bridge sent the configuration message
Max age	When the current configuration message will be deleted
Hello time	Time between root bridge messages
Forward delay	Time the bridges should wait before going to a new state



## STP Operation

# 802.1D BPDUs Propagation and Process

1. When a switch is powered on, it assumes it is the root bridge until BPDUs are sent and STP calculations are performed. S2 sends out BPDUs.
2. S3 compares its root ID with the BPDUs from S2. S2 is lower so S3 updates its root ID.

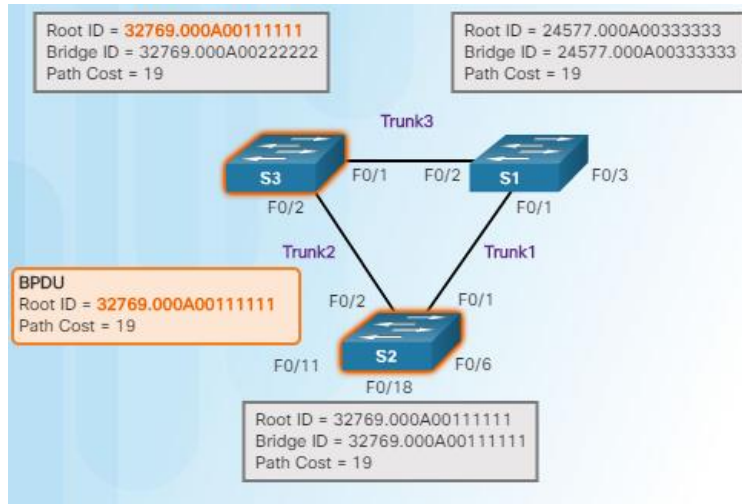
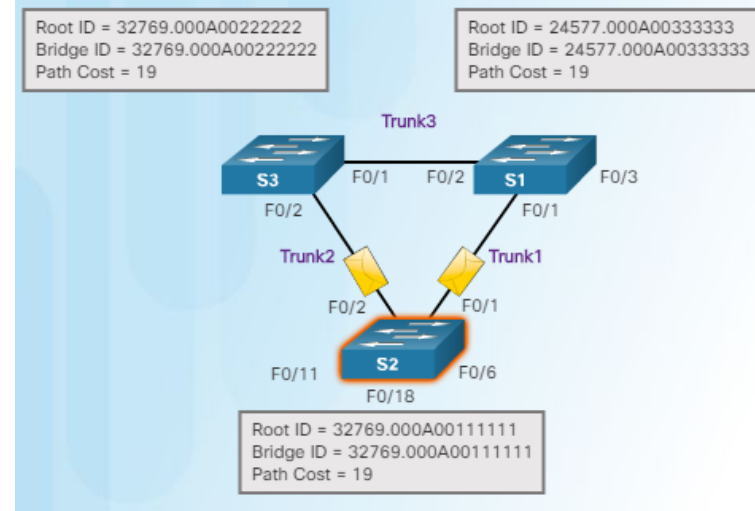

## STP Operation

# 802.1D BPDU Propagation and Process (Cont.)

- S1 receives the same information from S2 and because S1 has a lower BID, it ignores the information from S2.
- S3 sends BPDUs out all ports indicating that S2 is root bridge.

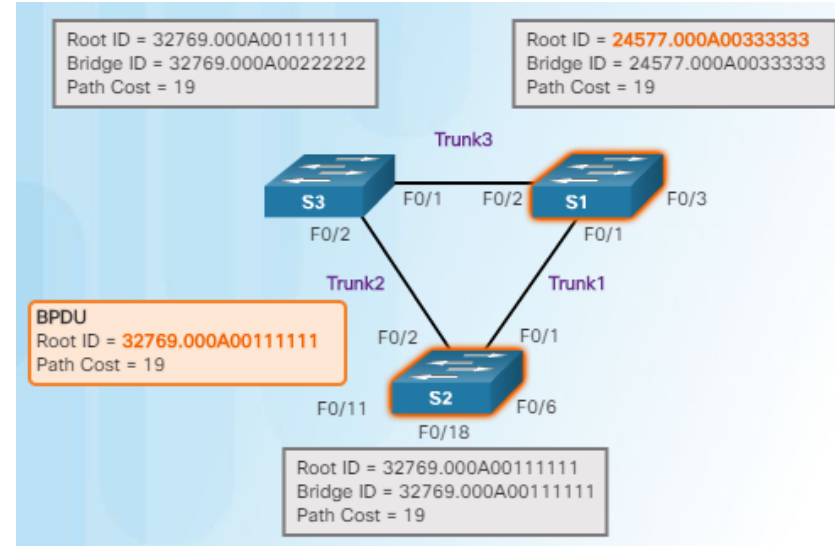
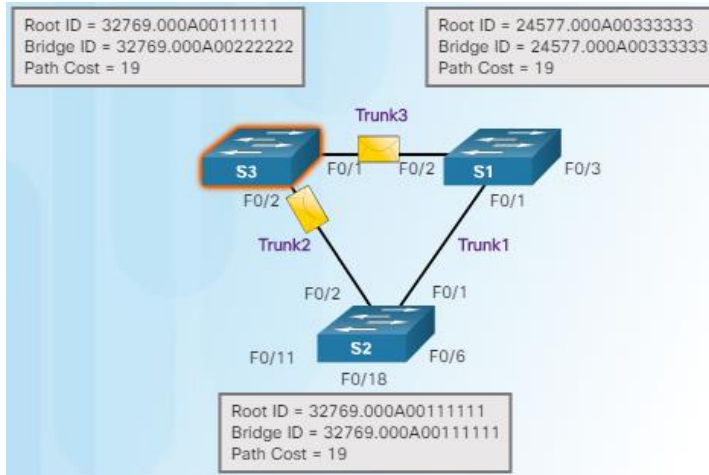

## STP Operation

# 802.1D BPDUs Propagation and Process (Cont.)

5. S2 compares the info from S3 so S2 still thinks it is root bridge.
6. S1 gets the same information from S3 (that S2 is root bridge), but because S1 has a lower BID, the switch ignores the information in the BPDUs.

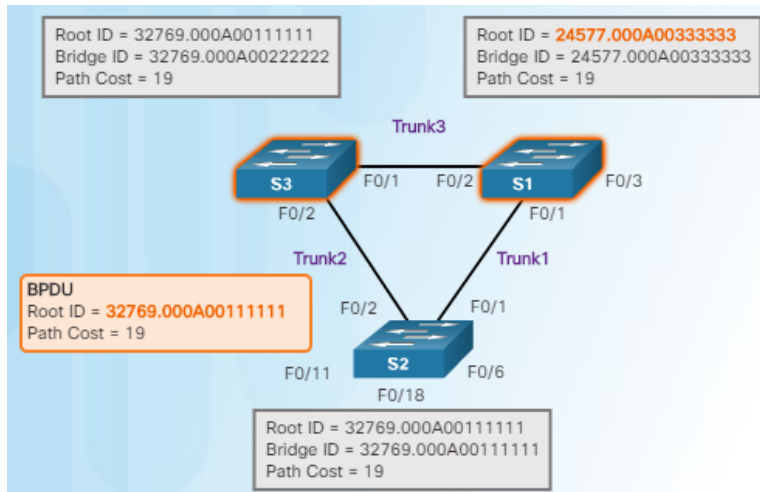
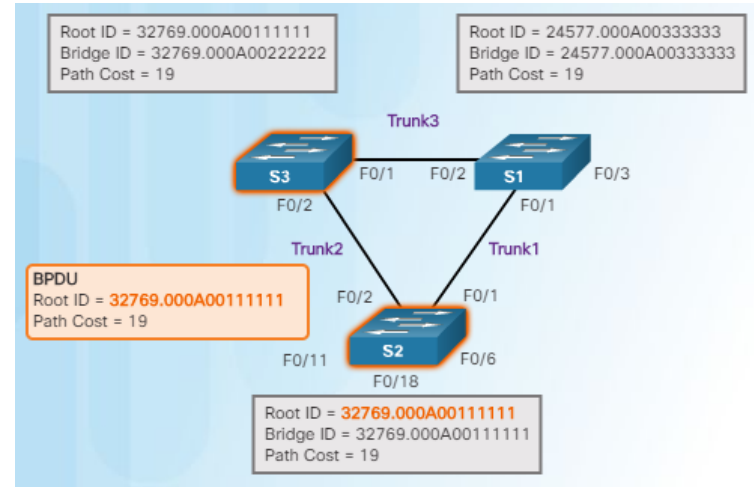

## STP Operation

# 802.1D BPDU Propagation and Process (Cont.)

7. S1 now sends out BPDUs out all ports. The BPDU contains information designated S1 as root bridge.

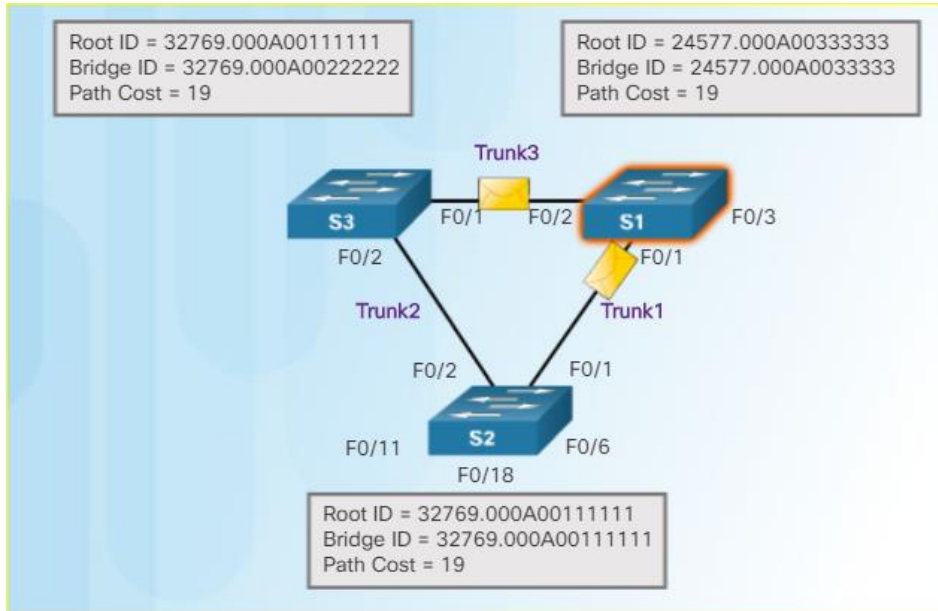

## STP Operation

# 802.1D BPDUs Propagation and Process (Cont.)

8. S3 compares the info from S1 so S3 now sees that the BID from S1 is lower than its stored root bridge information which is currently showing that S2 is root bridge. S3 changes the root ID to the information received from S1.
9. S2 compares the info from S1 so S2 now sees the BID from S1 is lower than its own BID. S2 now updates its own information showing S1 as root bridge.

Remember that after root bridge has been determined, the other port roles can be determined because those roles are determined by total path cost back to root bridge.

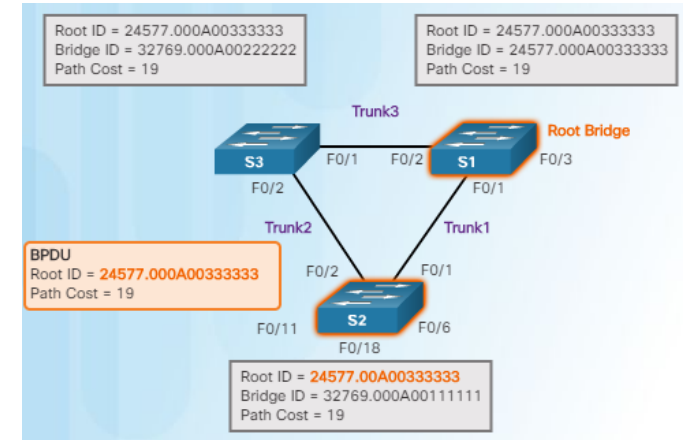
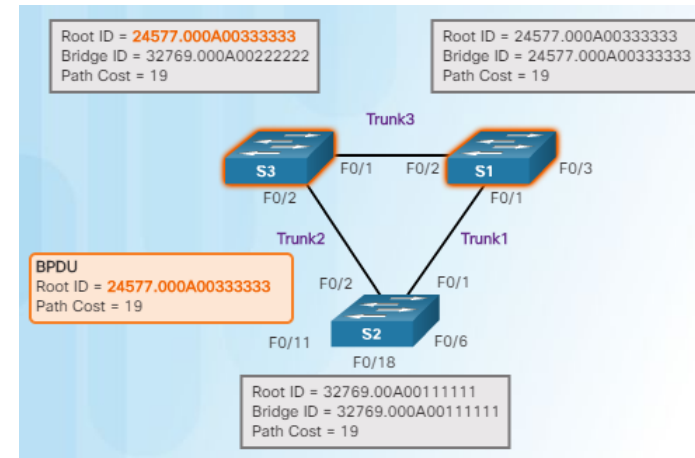

# STP Operation

## Extended System ID

Remember -  
lowest BID  
becomes root

- If priorities are all set to the default, lowest MAC address is the determining factor in lowest BID.
- The priority value can be modified to influence root bridge elections.

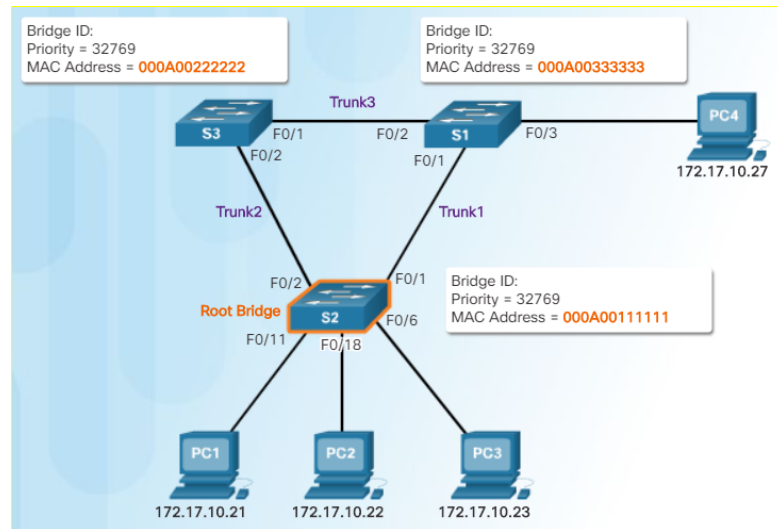
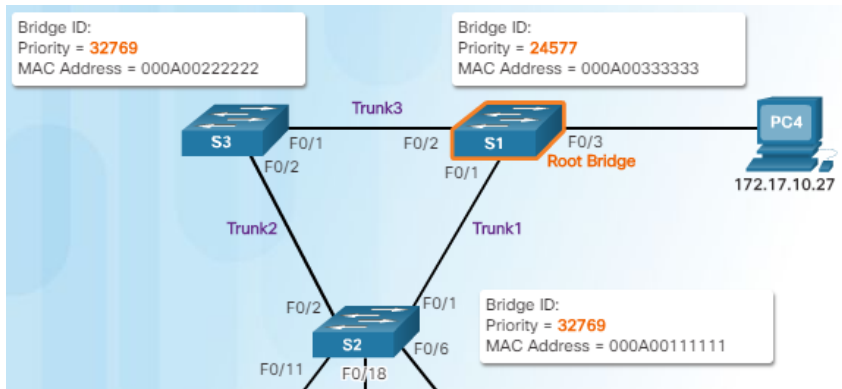
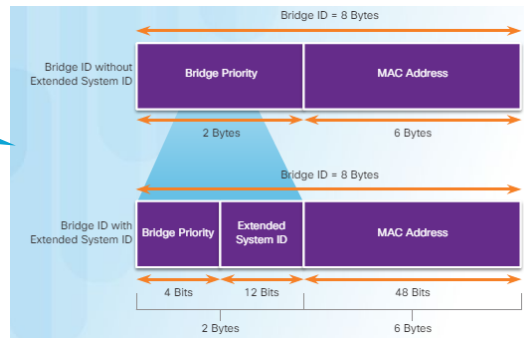

# 3.2 Types of Spanning Tree Protocols

# Types of Spanning Tree Protocols

STP Type	Description
802.1D	1998 - Original STP standard
CST	One spanning-tree instance
PVST+	Cisco update to 802.1D; each VLAN has its own spanning-tree instance
802.1D	2004 – Updated bridging and STP standard
802.1w (RSTP)	Improves convergence by adding new roles to ports and enhancing BPDU exchange
Rapid PVST+	Cisco enhancement of RSTP using PVST+
802.1s (MSTP)	Multiple VLANs can have the same spanning-tree instance



# Characteristics of Spanning Tree Protocols

STP Type	Standard	Resources Needed	Convergence	Tree Calculation
STP	802.1D	Low	Slow	All VLANs
PVST+	Cisco	High	Slow	Per VLAN
RSTP	802.1w	Medium	Fast	All VLANs
Rapid PVST+	Cisco	Very high	Fast	Per VLAN
MSTP	802.1s	Medium or high	Fast	Per instance

# Varieties of Spanning Tree Protocols

## Overview of PVST+

- Original 802.1D defines a common spanning tree
  - One spanning tree instance for the switched network (no matter how many VLANs)
  - No load sharing
  - One uplink must block for all VLANs
  - Low CPU utilization because only one instance of STP is used/calculated
- Cisco PVST+ - each VLAN has its own spanning tree instance
  - One port can be blocking for one VLAN and forwarding for another VLAN
  - Can load balance
  - Can stress the CPU if a large number of VLANs are used

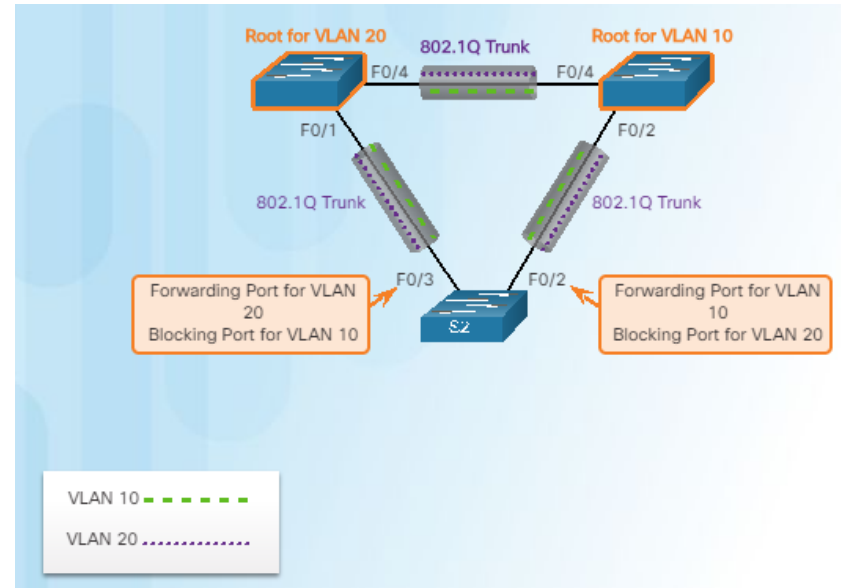

# Port States and PVST+ Operation

	Port State				
Operation allowed	Blocking	Listening	Learning	Forwarding	Disabled
Can receive/process BPDUs	Yes	Yes	Yes	Yes	No
Can forward data frames received on an interface	No	No	No	Yes	No
Can forward data frames switched from another interface	No	No	No	Yes	No
Can learn MAC addresses	No	No	Yes	Yes	No

# Extended System ID and PVST+ Operation

- The extended system ID field ensures each switch has a unique BID for each VLAN.
- The VLAN number is added to the priority value.
  - Example – VLAN 2 priority is 32770 (default value of 32768 plus the VLAN number of 2 equals 32770)
  - Can modify the priority number to influence the root bridge decision process
- Reasons to select a particular switch as root bridge
  - Switch is positioned such that most traffic patterns flow toward this particular switch
  - Switch has more processing power (better CPU)
  - Switch is easier to access and manage remotely

Remember that the BID is a unique ID

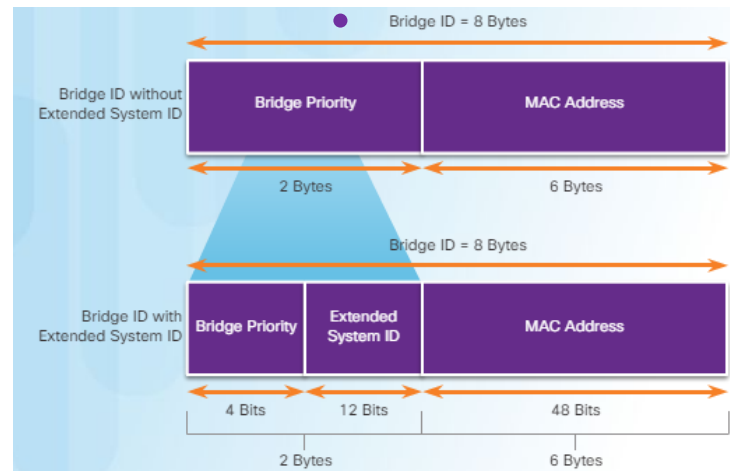

# Varieties of Spanning Tree Protocols

## Overview of Rapid PVST+

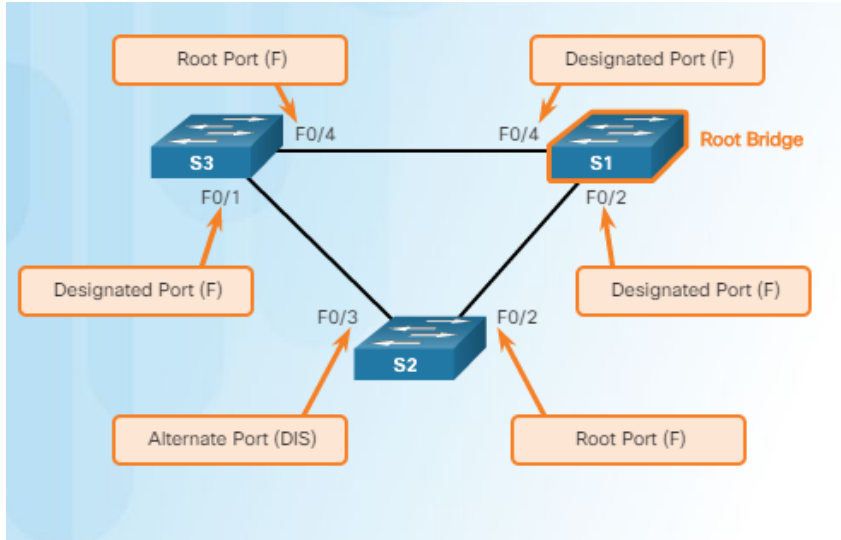

- Rapid PVST+ speeds up STP recalculations and converges quicker
  - Cisco version of RSTP
- Two new port types
  - Alternate port (DIS)
  - Backup port
- Independent instance of RSTP runs for each VLAN
- Cisco features such as UplinkFast and BackboneFast are not compatible with switches that run RSTP

# Varieties of Spanning Tree Protocols

## RSTP BPDUs

- RSTP uses type 2, version 2 BPDUs
  - Original version was type 0, version 0
- A switch using RSTP can work with and communicate with a switch running the original 802.1D version
- BPDUs are used as a keepalive mechanism
  - 3 missed BPDUs indicates lost connectivity

RSTP Version 2 BPDU	
Field	Byte Length
Protocol ID=0x0000	2
Protocol Version ID=0x02	1
BPDU Type=0x02	1
<b>Flags</b>	<b>1</b>
Root ID	8
Root Path Cost	4
Bridge ID	8
Port ID	2
Message Age	2
Max Age	2
Hello Time	2
Forward Delay	2

  

Flag Field	
Field Bit	Bit
Topology Change	0
Proposal	1
Port Role	2-3
Unknown Port	00
Alternate or Backup Port	01
Root Port	10
Designated Port	11
Learning	4
Forwarding	5
Agreement	6
Topology Change Acknowledgment	7

# Varieties of Spanning Tree Protocols

## Edge Ports

- Has an end device connected – **NEVER** another switch
- Immediately goes to the forwarding state
- Functions similar to a port configured with Cisco PortFast
- Use the **spanning-tree portfast** command

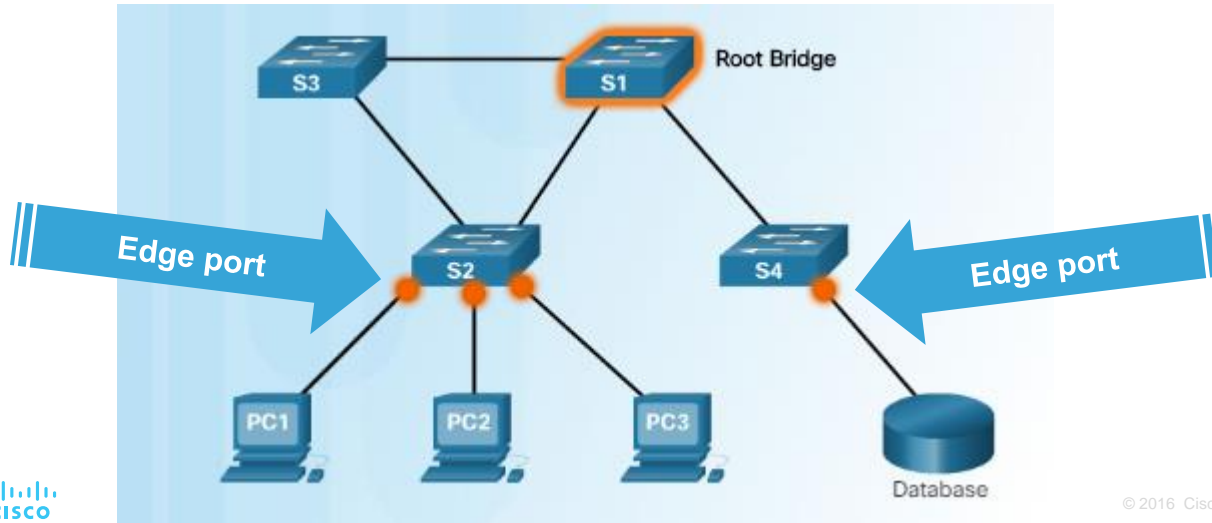

## Link Types

- Point-to-Point – a port in full-duplex mode connecting from one switch to another switch or from a device to a switch
- Shared – a port in half-duplex mode connecting a hub to a switch

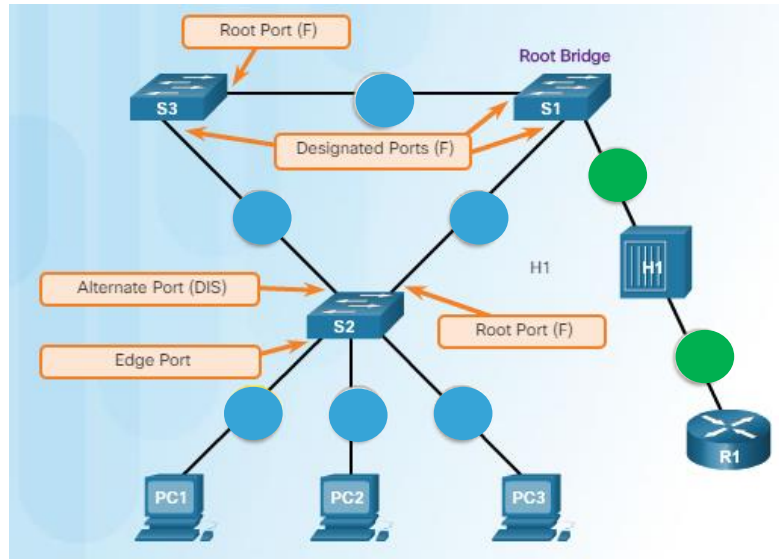

- Point-to-Point
- Shared



# 3.3 Spanning Tree Configuration

# Catalyst 2960 Default Configuration

Feature	Default Setting
Enable state	Enabled on VLAN 1
Spanning-tree mode	PVST+ (Rapid PVST+ and MSTP are disabled)
Switch priority	32768
Spanning-tree port priority (configurable on a per-interface basis)	128
Spanning-tree port cost (configurable on a per-interface basis)	1000 Mb/s: 4 100 Mb/s: 19 10 Mb/s: 100
Spanning-tree VLAN port priority (configurable on a per-VLAN basis)	128
Spanning-tree VLAN port cost (configurable on a per-VLAN basis)	1000 Mb/s: 4 100 Mb/s: 19 10 Mb/s: 100
Spanning-tree timers	Hello time: 2 seconds Forward-delay time: 15 seconds Maximum-aging time: 20 seconds Transmit hold count: 6 BPDUs

## Configuring and Verifying the Bridge ID

- Two ways to influence the root bridge election process
  - Use the **spanning-tree vlan x root primary** or **secondary** command.
  - Change the priority value by using the **spanning-tree vlan x priority x** command.
- Verify the bridge ID and root bridge election by using the **show spanning-tree** command.

```
S3# show spanning-tree
VLAN0001
Spanning tree enabled protocol ieee
Root ID    Priority    24577
           Address    00A.0033.3333
           This bridge is the root
           Hello Time 2 sec Max Age 20 sec Forward Delay 15 sec
Bridge ID  Priority    24577 (priority 24576 sys-id-ext 1)
           Address    00A.0033.3333
           Hello Time 2 sec Max Age 20 sec Forward Delay 15 sec
           Aging Time 300

Interface Role Sts Cost Prio.Nbr Type
-----
Fa0/1    Desg FWD 4    128.1  p2p
Fa0/2    Desg FWD 4    128.2  p2p
```

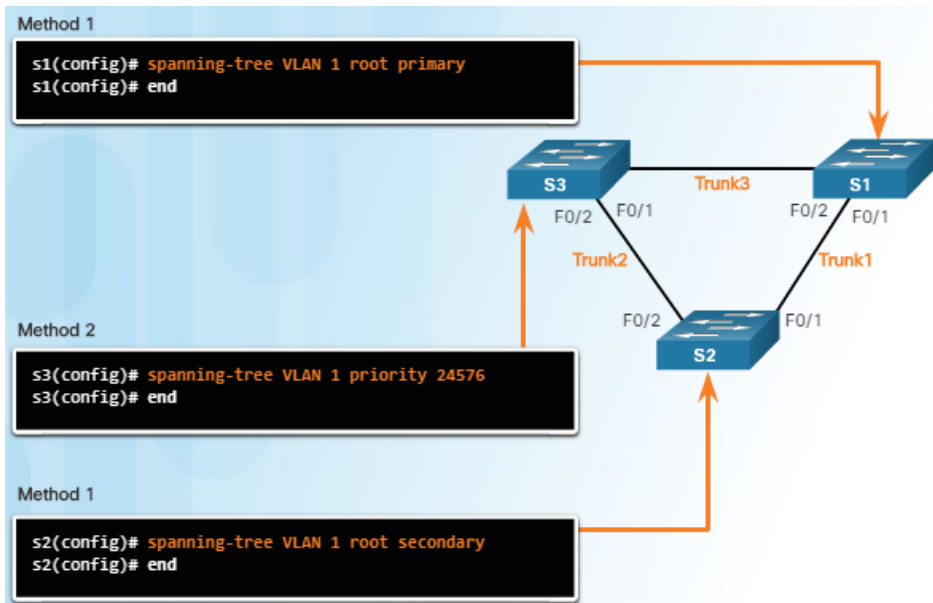

## PortFast and BPDU Guard

- PortFast is used on ports that have end devices attached.
  - Puts a port in the forwarding state
  - Allows DHCP to work properly
- BPDU Guard disables a port that has PortFast configured on it if a BPDU is received

```
S2(config)# interface FastEthernet 0/11
S2(config-if)# spanning-tree portfast
%Warning: portfast should only be enabled on ports connected to a single host.
Connecting hubs, concentrators, switches, bridges, etc... to this interface
when portfast is enabled, can cause temporary bridging loops.
Use with CAUTION
```

```
%Portfast has been configured on FastEthernet0/11 but will only
have effect when the interface is in a non-trunking mode.
```

```
S2(config-if)# spanning-tree bpduguard enable
```

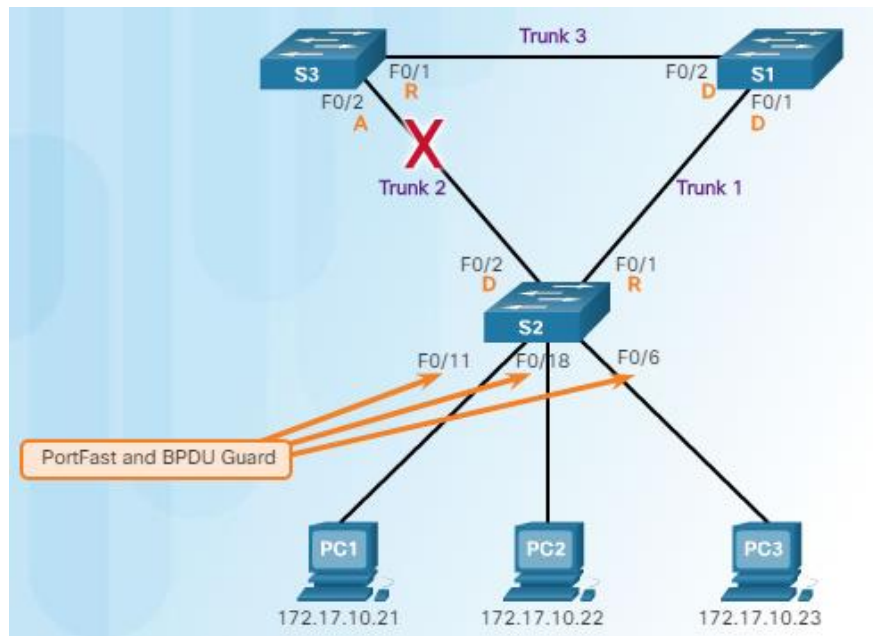

```
S2# show running-config interface f0/11
Building configuration...
```

```
Current configuration : 90 bytes
!
interface FastEthernet0/11
spanning-tree portfast
spanning-tree bpduguard enable
```

# PVST+ Configuration

## PVST+ Load Balancing

```
S3(config)# spanning-tree vlan 20 root primary
S3(config)# spanning-tree vlan 10 root secondary
```

Or

```
S3(config)# spanning-tree vlan 20 priority 4096
```

```
S1(config)# spanning-tree vlan 10 root primary
S1(config)# spanning-tree vlan 20 root secondary
```

Or

```
S1(config)# spanning-tree vlan 10 priority 4096
```

```
S1# show spanning-tree active
<output omitted>

VLAN0010
Spanning tree enabled protocol ieee
Root ID    Priority    4106
           Address    0019.aa9e.b000
           This bridge is the root
Hello Time 2 sec Max Age 20 sec Forward Delay 15 sec
Bridge ID  Priority    4106 (priority 4096 sys-id-ext 10)
           Address    0019.aa9e.b000
Hello Time 2 sec Max Age 20 sec Forward Delay 15 sec
Aging Time 300

Interface Role Sts Cost Prio.Nbr Type
-----
Fa0/2    Desg FWD 19    128.2  p2p
Fa0/4    Desg FWD 19    128.4  p2p
```

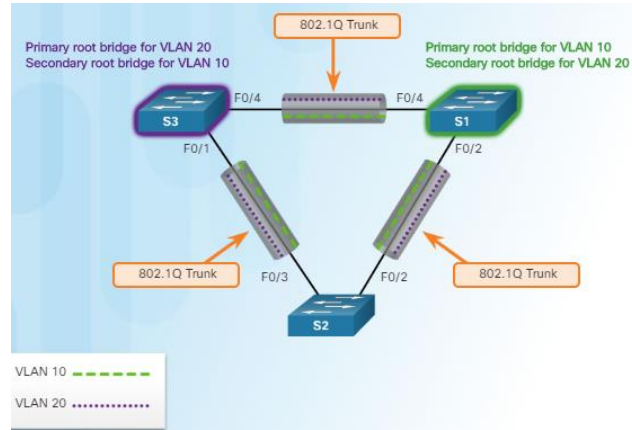

```
S1# show running-config
Building configuration...

Current configuration : 1595 bytes
!
version 12.2
<output omitted>
!
spanning-tree mode pvst
spanning-tree extend system-id
spanning-tree vlan 1 priority 24576
spanning-tree vlan 10 priority 4096
spanning-tree vlan 20 priority 28672
```

# Rapid PVST+ Configuration

## Spanning Tree Mode

- Rapid PVST+ supports RSTP on a per-VLAN basis.
  - Default on a 2960 is PVST+.
  - The **spanning-tree mode rapid-pvst** puts a switch into Rapid PVST+ mode.
  - The **spanning-tree link-type point-to-point** interface command designates a particular port as a point-to-point link (does not have a hub attached).
  - The **clear spanning-tree detected-protocols** privileged mode command is used to clear STP.

```
S1# configure terminal
S1(config)# spanning-tree mode rapid-pvst
S1(config)# interface f0/2
S1(config-if)# spanning-tree link-type point-to-point
S1(config-if)# end
S1# clear spanning-tree detected-protocols
```

```
S1# show run
<output omitted>
spanning-tree mode rapid-pvst
spanning-tree extend system-id
spanning-tree vlan 1 priority 24576
spanning-tree vlan 10 priority 4096
spanning-tree vlan 20 priority 28672
```

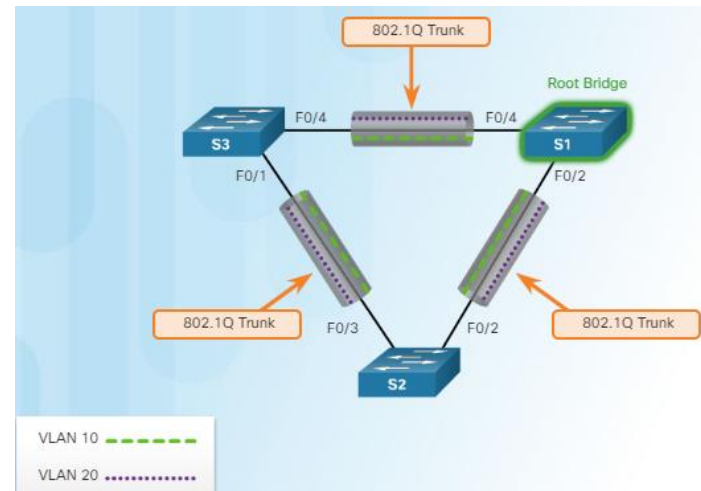

```
S1# show spanning-tree vlan 10
```

```
VLAN0010
Spanning tree enabled protocol rstp
Root ID    Priority    4106
Address    0019.aa9e.b000
This bridge is the root
Hello Time 2 sec Max Age 20 sec Forward Delay 15 sec
Bridge ID  Priority    4106 (priority 4096 sys-id-ext 10)
Address    0019.aa9e.b000
Hello Time 2 sec Max Age 20 sec Forward Delay 15 sec
Aging Time 300
Interface  Role Sts Cost      Prio.Nbr Type
-----
Fa0/2     Desg LRN 19        128.2    P2p
Fa0/4     Desg LRN 19        128.4    P2p
```

# STP Configuration Issues

## Analyzing the STP Topology

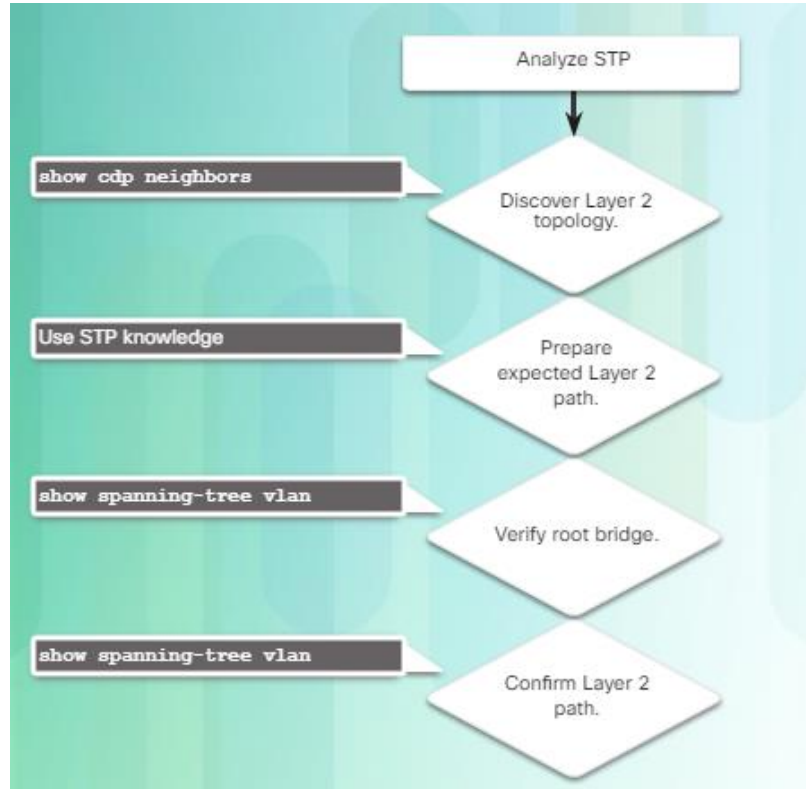

# Expected Topology Versus Actual Topology

- Ensure that the spanning-tree topology matches what is expected.

Use **show** commands to verify STP. Do not forget to verify load balancing.

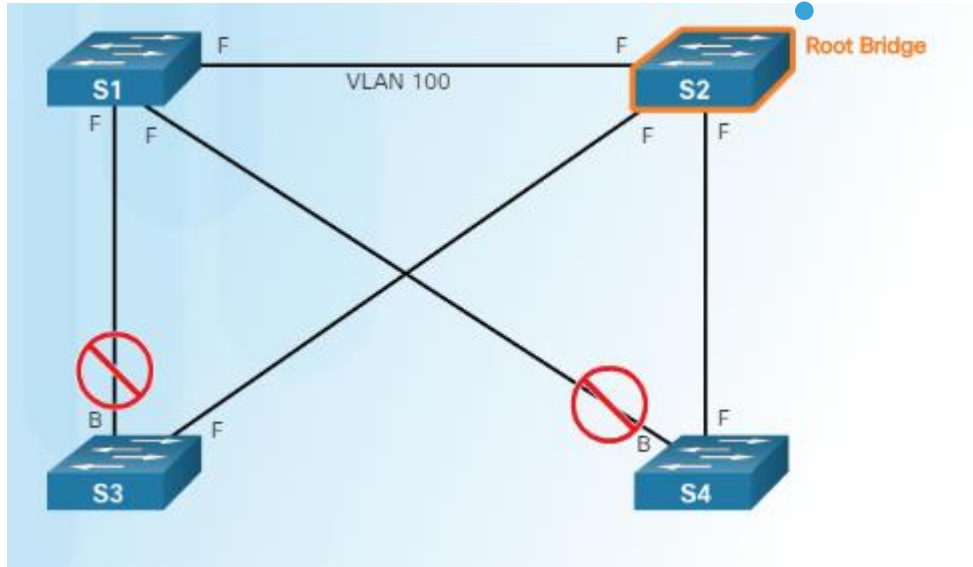



# STP Configuration Issues

## Overview of STP Status

- Use the **show spanning-tree** and **show spanning-tree vlan x** commands to verify the STP status.

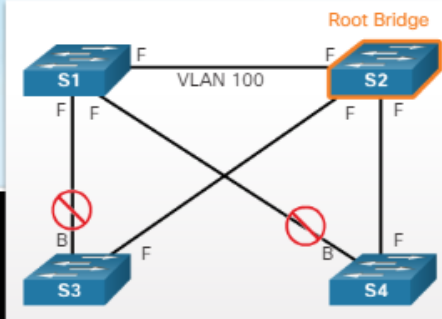

```
S1# show spanning-tree vlan 100

VLAN0100
Spanning tree enabled protocol rstp
Root ID    Priority    28772
          Address    0000.0c9f.3127
          Cost      2
          Port      88 (TenGigabit9/1)
          Hello Time 2 sec Max Age 20 sec Forward Delay 15 sec
Bridge ID  Priority    28772 (priority 28672 sys-id-ext 100)
          Address    0000.0cab.3724
          Hello Time 2 sec Max Age 20 sec Forward Delay 15 sec
          Aging Time 300

Interface   Role Sts Cost      Prio.Nbr Type
-----
Gi3/1       Desg FWD 4         128.72   P2p
Gi3/2       Desg FWD 4         128.80   P2p
Te9/1       Root FWD 2         128.88   P2p
```

Ten gigabit Ethernet interface

# STP Configuration Issues

## Spanning Tree Failure Consequences

- NEVER turn STP off; this can cause a switched network to be unusable – Remember that there is not a TTL mechanism at Layer 2.

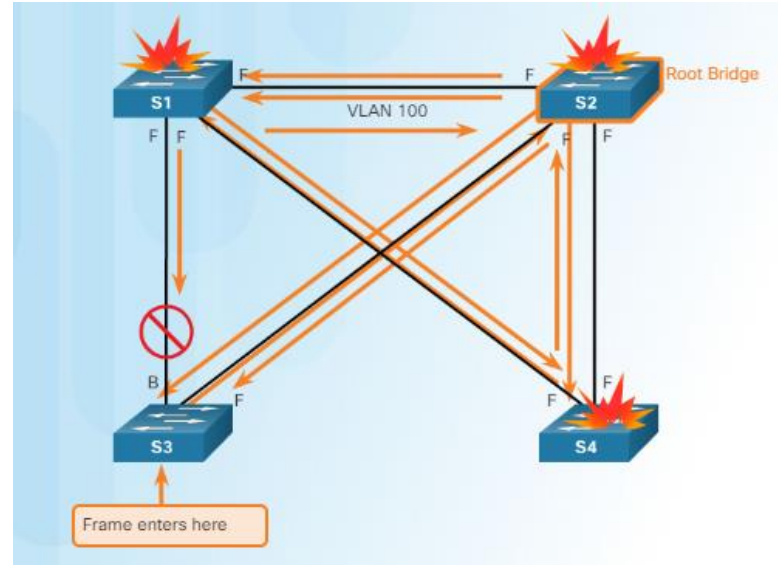
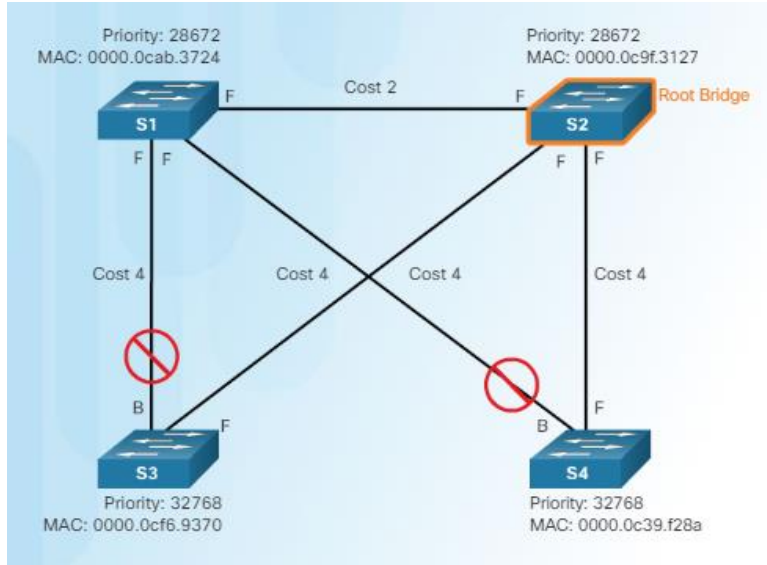

# Repairing a Spanning Tree Problem

- Manually remove redundant links (physically remove the cable OR through configuration, if possible).
  - Determine and repair the cause of the spanning tree failure.
  - If unable to determine the problem, reinstall cables one at a time (or re-enable the ports) to locate the issue.

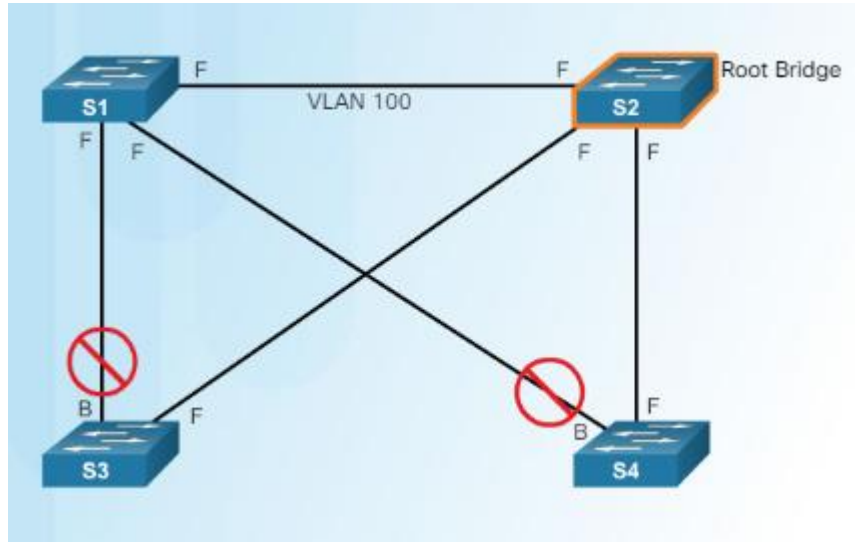

# Switch Stacking and Chassis Aggregation

## Switch Stacking Concepts

- Can connect up to nine 3750 switches
- One switch (the stack master) controls the operation of the stack
  - If this switch goes down, a new stack master is elected
- Appears as one entity to the network
  - Stack is assigned one IP address
- Each switch has a unique stack member number
  - Can configure a priority value to determine which switch is stack master
  - Highest stack member priority value is stack master
- The stack master has the saved and running configuration files for the entire stack.
  - Only one configuration file to manage and maintain



```
Switch# show running-config | begin interface
interface GigabitEthernet1/0/1
!
interface GigabitEthernet1/0/2
!
interface GigabitEthernet1/0/3
!
<output omitted>
!
interface GigabitEthernet1/0/52
!
interface GigabitEthernet2/0/1
!
interface GigabitEthernet2/0/2
!
<output omitted>
!
interface GigabitEthernet2/0/52
!
interface GigabitEthernet3/0/1
!
interface GigabitEthernet3/0/2
!
<output omitted>
!
interface GigabitEthernet3/0/52
```

# Switch Stacking and Chassis Aggregation

## Spanning Tree and Switch Stacks

- Each stack appears as one spanning tree instance
- Can add switches without affecting the STP diameter (the maximum number of switches data must cross to connect between any two switches)
- IEEE recommends a maximum diameter of 7 switches for default STP timers
- Default STP timers are hello – 2 seconds, max age – 20 seconds, forward delay timer – 15 seconds

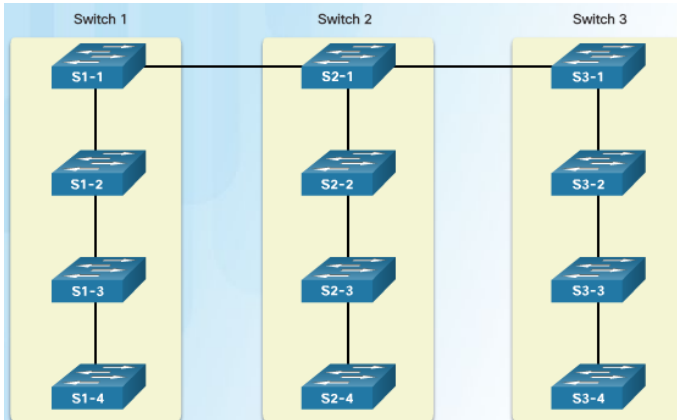
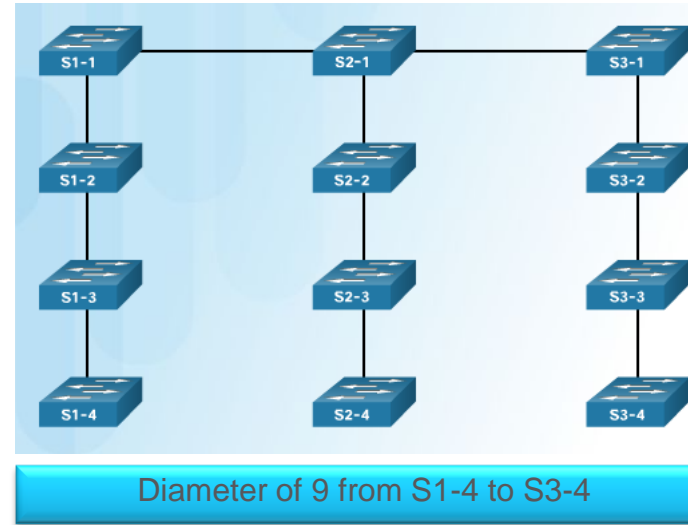

# 9.4 Chapter Summary

## Chapter 3: STP

- Build a simple switched network with redundant links.
- Explain how different varieties of spanning tree protocols operate
- Implement PVST+ and Rapid PVST+ in a switched LAN environment.

